

Bright Toaster Set

Assembly Instructions

Item #63176

Please retain this information for future reference

To order replacement parts, please visit www.kidkraft.com

PARTS LIST:

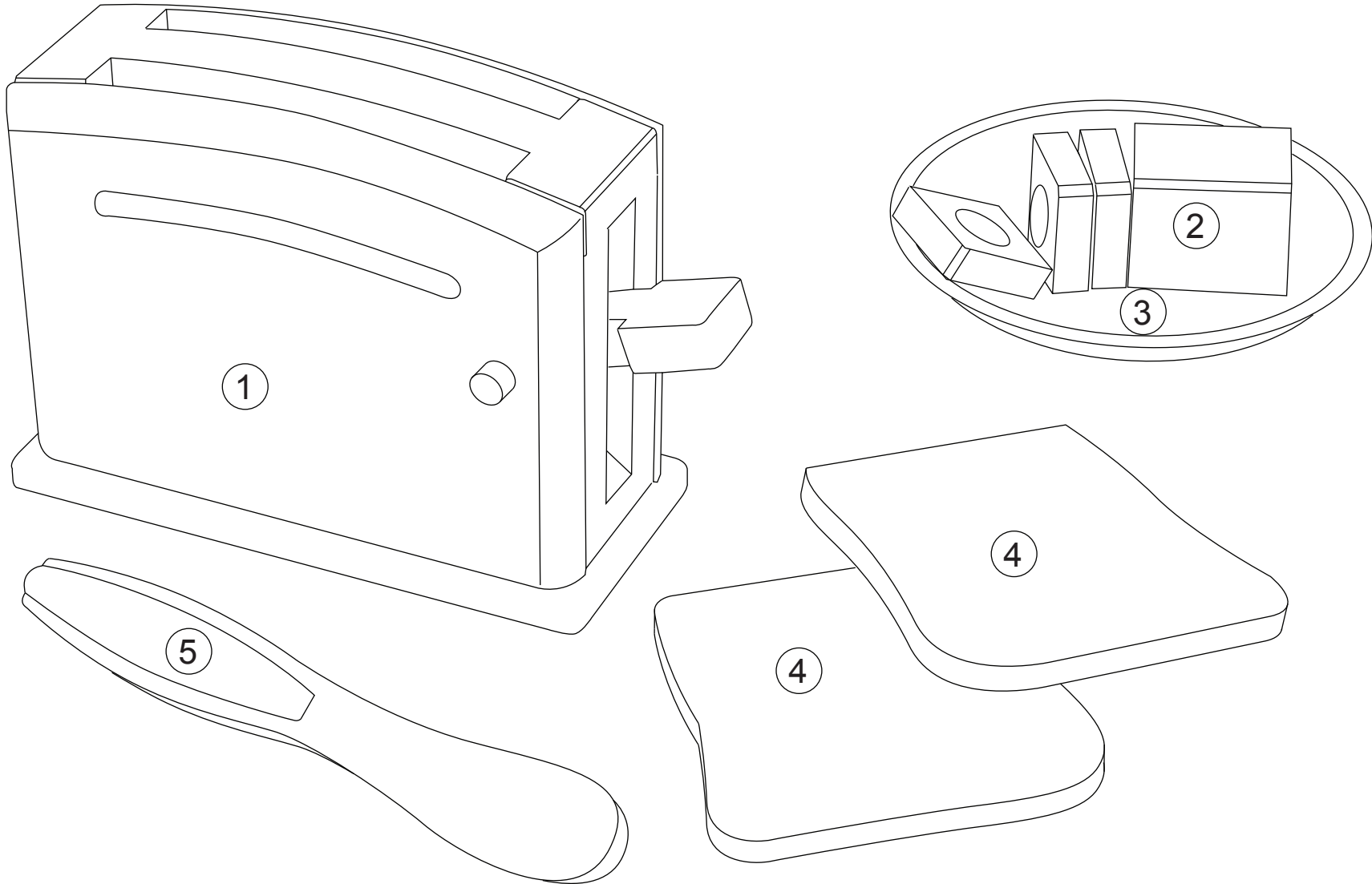

Customer Service
1-800-933-0771
www.kidkraft.com



IMPORTANT INFORMATION - PLEASE READ FIRST

ALL OF OUR WOODEN ITEMS ARE HANDCRAFTED, HAND ASSEMBLED, AND HAND PAINTED. EACH ONE IS UNIQUE. SLIGHT IMPERFECTIONS MAY OCCUR AND ARE NOT MANUFACTURING DEFECTS.

PLEASE NOTE THAT WE DO NOT WARRANTY AGAINST THE USE OF PERMANENT MARKERS, NON-WATER-BASED PAINTS, CRAYONS, OR WASHABLE MARKERS. SOME OF THESE ITEMS CONTAIN PERMANENT COLOR DYES THAT COULD DAMAGE THE SURFACE.

CLEANING INSTRUCTIONS

CLEAN THE SURFACE USING A SLIGHTLY DAMP CLOTH AND MILD DISH WASHING LIQUID IF NECESSARY. DO NOT USE ANY CLEANING PRODUCT CONTAINING ALCOHOL OR AMMONIA. THESE WILL DULL THE SHINY SURFACE OF THE PRODUCT. FURNITURE POLISH WILL ALSO WORK TO CLEAN AND DUST OFF THE SURFACE.

WE RECOMMEND THAT YOU TEST ALL CLEANING MATERIALS ON THE UNDERSIDE OF ANY SURFACE THAT WOULD NOT BE SEEN DURING NORMAL USE OF THE PRODUCT. IF YOU HAVE QUESTIONS REGARDING THE MAINTENANCE OF THIS PRODUCT PLEASE FEEL FREE TO CALL US.

SOLE AND LIMITED WARRANTY

THIS TOY IS WARRANTED SOLELY AGAINST MANUFACTURING DEFECTS FOR A PERIOD OF 90 DAYS FROM THE DATE OF PURCHASE, WHICH WARRANTY RUNS ONLY TO THE ORIGINAL USER OF THE TOY. IN THE EVENT OF A MANUFACTURING DEFECT, THE TOY WILL BE REPLACED OR THE PURCHASE PRICE REFUNDED, AT THE ELECTION OF THE MANUFACTURER. TO ACTIVATE AND PROTECT THIS WARRANTY, PRESERVE EVIDENCE OF ORIGINAL PURCHASE AND CAREFULLY INSPECT THE CONDITION OF THE TOY PRIOR TO AND AFTER ASSEMBLY, LOOKING FOR MISSING, DEGRADED, BROKEN OR HAZARDOUS PARTS, INCLUDING PARTS WHICH CAN BE SWALLOWED BY A CHILD, CAUSE A CHILD TO CHOKe, OR OTHERWISE CAUSE INJURY. SUCH PARTS MAY INCLUDE MAGNETS, WHEELS, HUBS, FASTENERS, AND CONNECTORS. SHOULD YOU OBSERVE ANY DEFECTS, DO NOT USE THE TOY AND IMMEDIATELY NOTIFY THE MANUFACTURER. FAILURE TO DO SO SHALL CONSTITUTE MISUSE. MISUSE, IMPROPER ASSEMBLY, FAILURE TO HONOR A WARNING, FAILURE TO SUPERVISE, INSPECT OR MAINTAIN THE TOY, OR DAMAGE TO THE TOY, WHETHER INTENTIONAL OR INADVERTENT, SHALL INVALIDATE THIS WARRANTY.

TO SUBMIT A WARRANTY CLAIM PLEASE CONTACT KIDKRAFT CUSTOMER SERVICE AT 1-800-933-0771 FOR INSTRUCTIONS ON HOW TO PROVIDE PROOF OF PURCHASE AND HOW TO RETURN THE ITEM FREIGHT PRE-PAID.

CUSTOMER SERVICE 1-800-933-0771

www.kidkraft.com